

Grizzly **Industrial, Inc.** ®

RECIPROCATING SAW MODEL H0799 INSTRUCTION MANUAL



COPYRIGHT © 2000 BY GRIZZLY INDUSTRIAL, INC.
**WARNING: NO PORTION OF THIS MANUAL MAY BE REPRODUCED IN ANY SHAPE
OR FORM WITHOUT THE WRITTEN APPROVAL OF GRIZZLY INDUSTRIAL, INC.**
#313100624 REVISED APRIL, 2003. PRINTED IN CHINA

SAFETY

WARNING

For Your Own Safety Read Instruction Manual Before Operating This Equipment

The purpose of safety symbols is to attract your attention to possible hazardous conditions. This manual uses a series of symbols and signal words which are intended to convey the level of importance of the safety messages. The progression of symbols is described below. Remember that safety messages by themselves do not eliminate danger and are not a substitute for proper accident prevention measures.

DANGER

Indicates an imminently hazardous situation which, if not avoided, WILL result in death or serious injury.

WARNING

Indicates a potentially hazardous situation which, if not avoided, COULD result in death or serious injury.

CAUTION

Indicates a potentially hazardous situation which, if not avoided, MAY result in minor or moderate injury. It may also be used to alert against unsafe practices.

NOTICE

This symbol is used to alert the user to useful information about proper operation of the equipment.

WARNING

Safety Instructions For Power Tools

- 1. KEEP ALL SAFETY DEVICES IN PLACE** and in working order.
- 2. REMOVE ADJUSTING KEYS AND WRENCHES.** Form habit of checking to see that keys and adjusting wrenches are removed from tool before turning on.
- 3. KEEP WORK AREA CLEAN.** Cluttered areas and benches invite accidents.
- 4. DON'T USE IN DANGEROUS ENVIRONMENT.** Don't use power tools in damp or wet locations, or where any flammable or noxious fumes may exist. Keep work area well lighted.
- 5. KEEP CHILDREN AND VISITORS AWAY.** All children and visitors should be kept a safe distance from work area.
- 6. MAKE WORK SHOP CHILD PROOF** with padlocks, master switches, or by removing starter keys.
- 7. DON'T FORCE TOOL.** It will do the job better and safer at the rate for which it was designed.
- 8. USE RIGHT TOOL.** Don't force tool or attachment to do a job for which it was not designed.

WARNING

Safety Instructions For Power Tools

- 9. USE PROPER EXTENSION CORD** for the tool. Make sure your extension cord is in good condition. Conductor size should be in accordance with the chart below. The amperage rating should be listed on the motor or tool nameplate. An undersized cord will cause a drop in line voltage resulting in loss of power and overheating. Your extension cord must also contain a ground wire and plug pin. Always repair or replace extension cords if they become damaged.

Minimum Gauge for Extension Cords

AMP RATING	LENGTH		
	25ft	50ft	100ft
0-6	18	16	16
7-10	18	16	14
11-12	16	16	14
13-16	14	12	12
17-20	12	12	10
21-30	10	10	No

- 10. WEAR PROPER APPAREL.** Do not wear loose clothing, gloves, neckties, rings, bracelets, or other jewelry which may get caught in moving parts. Non-slip footwear is recommended. Wear protective hair covering to contain long hair.
- 11. ALWAYS USE SAFETY GLASSES.** Also use face or dust mask if cutting operation is dusty. Everyday eyeglasses only have impact resistant lenses, they are NOT safety glasses.
- 12. SECURE WORK.** Use clamps or a vise to hold work when practical. It's safer than using your hand and frees both hands to operate tool.
- 13. DON'T OVERREACH.** Keep proper footing and balance at all times.

- 14. MAINTAIN TOOLS WITH CARE.** Keep tools sharp and clean for best and safest performance. Follow instructions for lubricating and changing accessories.
- 15. DISCONNECT TOOLS** before servicing and changing accessories, such as blades, bits, cutters, and the like.
- 16. REDUCE THE RISK OF UNINTENTIONAL STARTING.** Make sure switch is in off position before plugging in.
- 17. USE RECOMMENDED ACCESSORIES.** Consult the owner's manual for recommended accessories. The use of improper accessories may cause risk of injury.
- 18. CHECK DAMAGED PARTS.** Before further use of the tool, a guard or other part that is damaged should be carefully checked to determine that it will operate properly and perform its intended function. Check for alignment of moving parts, binding of moving parts, breakage of parts, mounting, and any other conditions that may affect its operation. A guard or other part that is damaged should be properly repaired or replaced.

INTRODUCTION

Commentary

We are proud to offer the Grizzly Model H0799 Reciprocating Saw. The Model H0799 is part of a growing Grizzly family of fine power tools. When used according to the guidelines set forth in this manual, you can expect years of trouble-free, enjoyable operation and proof of Grizzly's commitment to customer satisfaction.

The Model H0799 Reciprocating Saw, weighing 7¼ pounds, is heavy duty enough to perform all of your tough cutting jobs. The dial controlled variable speed adjustment lets you choose between 300-2000 strokes per minute. The Model H0799 also features 5.5 amp power with a 1¾" stroke, lock-on trigger and easy Allen® wrench blade changing capabilities.

We are pleased to provide this manual with the Model H0799. It was written to encourage safety considerations and guide you through general operating procedures and maintenance. It represents our effort to produce the best documentation possible.

The specifications, details, and photographs in this manual represent the Model H0799 as supplied when the manual was prepared. However, owing to Grizzly's policy of continuous improvement, changes may be made at any time with no obligation on the part of Grizzly. If you have any comments regarding this manual, please write to us at the address below:

Grizzly Industrial, Inc.
% Technical Documentation
P.O. Box 2069
Bellingham, WA 98227-206

Most importantly, we stand behind our tools. If you have any service questions or parts requests, please call or write us at the location listed below.

Grizzly Industrial, Inc.
1203 Lycoming Mall Circle
Muncy, PA 17756
Phone: (570) 546-9663
Fax: (800) 438-5901
E-Mail: techsupport@grizzly.com
Web Site: <http://www.grizzly.com>

CAUTION

To operate this, or any power tool, safely and efficiently, it is essential to become as familiar with its characteristics as possible. The time you invest before you begin to use your Model H0799 will be time well spent. DO NOT operate this machine until you are completely familiar with the contents of this manual. Make sure you read and understand all of the safety procedures. If you do not understand something, DO NOT operate the machine.

CAUTION

No list of safety guidelines can be complete. Every shop environment is different. Always consider safety first, as it applies to your individual working conditions. Use this and other machinery with caution and respect. Failure to do so could result in serious personal injury, damage to equipment or poor work results.

BEFORE YOU START

Contents

First review the contents of your H0799 Reciprocating Saw and familiarize yourself with the key components below:

- H0799 Reciprocating Saw
- Instruction Manual
- 3 mm Allen®
- 4 mm Allen®
- Coarse Tooth Saw Blade
(for wood cutting)
- Fine Tooth Saw Blade
(for metal cutting)
- 2 Replacement Setscrews

Technical Specifications

This tool is double insulated. A double independent insulation protects you against touching any parts that can be connected with live electrical current

Radio and television interference of this apparatus are suppressed according to the EN 55014 standard.

Volt	110V
Frequency	60Hz
H.P.	¾ H.P.
Amps	5.5
No load strokes	300-2000/min
Max. cutting thickness wood	4½"
Stroke	1⅜"
Weight	7¼ lbs

OPERATION

WARNING

Any time the saw is plugged into a power source, the reciprocating blade will activate when the trigger is depressed. Before making any adjustments or when changing blades, always remove the plug from the power source first. Failure to observe this will lead to serious personal injury.

Inserting and Removing Saw Blades:

1. Make sure saw is unplugged from power source.
2. Use the 3mm Allen® Wrench supplied to loosen the setscrew located in the slot on the left hand side of the saw (see **Figure 3** for location of controls). While it is not required to remove the screw, it does need to be turned three or four times to allow blades to be exchanged. Please note the locating pin under the jaw clamp. (**Figure 2**).
3. Remove the blade and replace with blade that has appropriate shank profile (see **Figure 1**). Make sure the blade has the correct tooth count per inch for the job to be done.
4. Tighten the screw while ensuring the locating pin remains in the hole provided for it in the blade.

Always check to see if the blade is secure after the setscrew is tight. Grasp the back side of the blade (the side without teeth) and gently try to move it side to side and back and forth. If the blade is found to be loose, remove the screw and reposition the blade.

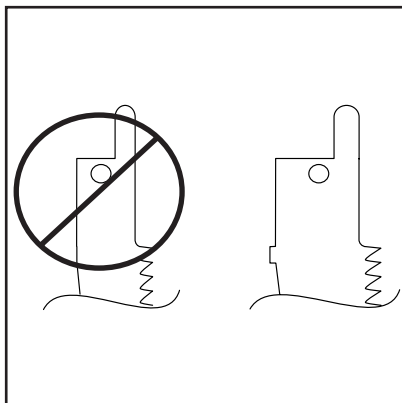

Fig 1. Always use correct shank profile.

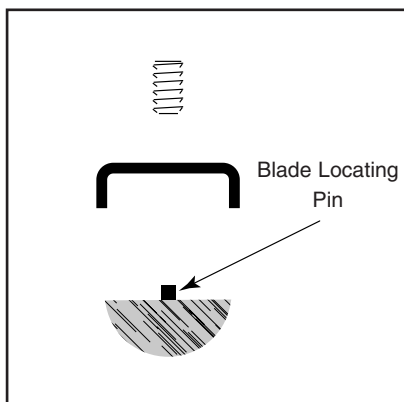

Fig 2. Blade Clamp Assembly.

Continuous Run Mode:

The trigger switch can be locked by pressing the button on the side of the handle. Squeeze the trigger switch until it has reached the required position and depress the lock on the knob. This will make the tool run continuously. Press the trigger switch to disengage the lock (see **Figure 3**).

OPERATION, CONT'D

Choosing the Right Blade:

The rule of thumb for choosing a blade for a given application is that the harder and/or thinner the material, the more teeth per inch are required. A list of TPI and materials to be cut follows.

TPI	Material
24	Sheet Metal / Stainless
14	Metal / Wood w/ Nails
10/14	Soft Metals / Wood
10	Wood
6	Rough Cut Wood

Choosing the Blade Speed:

Blade speed is controlled by the thumb wheel on top of the saw, above the trigger (see **Figure 3**). The higher the number on the thumbwheel, the faster the saw reciprocates.

Using the right blade and speed will allow faster cutting operation, longer blade life and will prolong the life of the saw. This will require practice on the part of the operator. If blade seems to dull quickly, replace and use slower blade speed. If cutting wood, most species allow faster speeds.

NOTE: When cutting metal, a suitable coolant must be used (cutting oil); otherwise it will cause unnecessary wear on the blade.

Stroke Length and Material Thickness:

The length of stroke for the H0799 Reciprocating Saw is 1 $\frac{3}{16}$ ". When material thickness exceeds 1 $\frac{3}{16}$ " the blade is unable to evacuate the chips being produced. Therefore, when cutting materials that are thicker than 1 $\frac{3}{16}$ " it may be necessary to "clear the blade" occasionally. Simply let go of the trigger and allow the blade to come to a complete stop. Extract the blade from the cut and the chips should fall away. Insert the blade into the cut and continue cutting.

⚠ CAUTION

Never extract or insert the blade into workpiece with the blade in motion. Serious personal injury will occur.

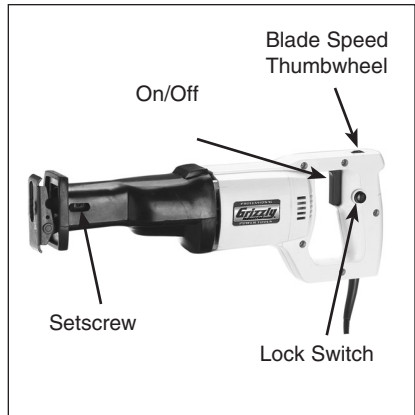

Fig 3. Location of controls.

⚠ WARNING

Operating this equipment has the potential to propel debris into the air which can cause eye injury. Always wear safety glasses or goggles when operating equipment. Be certain the safety glasses you wear meet the appropriate standards of the American National Standards Institute (ANSI).

OPERATING TIPS AND

Operating Guides and Tips

Avoid overloading the saw. Always use sharp blades. Do not apply excessive pressure to the saw while using. If the speed drops abnormally, decrease pressure immediately. If the blade stops abruptly or becomes locked, release the trigger at once. Extract the blade and determine what occurred to cause this and rectify.

Ensure the safety of the workplace. Ensure the saw blade will not pass through bench or saw horse that workpiece may be on. Securely fix smaller objects to be cut in a vise or otherwise clamp to avoid injury. Do not attempt to hold workpiece by hand.

Avoid blade pinch. Saw blades may become pinched while cutting a workpiece that is improperly supported, very thick workpieces or when several workpieces are loosely stacked. Know how to avoid these situations to minimize risk of damage to the saw, saw blade or personal injury.

Inspect the saw before use. Run the saw before using to ensure all parts are running smoothly and there are no abnormal sounds or sparks. If any defect is found, have unit serviced.

Know your worksite. Only cut as deep as necessary. Be extremely careful when cutting behind walls for wires, other electrical hazards, gas lines, or plumbing.

Use accessories properly. Use the right blade for the job. Be aware of blade TPI necessary for the type and thickness of the material. Use the appropriate blade speed- when in doubt slow the blade speed.

Maintenance

Your H0799 Reciprocating saw will give you hundreds of hours of operation time before ever needing service. The electrical components of this saw are not user serviceable. Repair should always be undertaken by a qualified electrical repair technician.

Keep the saw free from dirt and grease. Before cleaning or carrying out maintenance operations, always disconnect the tool. Never use water or other liquids to clean electrical components of the tool. Remember that regular maintenance will prevent unnecessary problems.

Keep the bottom plate clean to avoid inaccurate cuts.

Keep the exterior of the tool clean to make sure all moving parts move accurately and without wear.

Keep the ventilating slots of the motor clean to prevent the motor from overheating.

WARNING

Disassembly and improper reassembly of this device can result in electrical shock danger. Always have this device serviced by an qualified electrical repair technician. Serious injury will result.

WARRANTY AND RETURNS

Grizzly Industrial, Inc. warrants every product it sells for a period of 1 year to the original purchaser from the date of purchase. This warranty does not apply to defects due directly or indirectly to misuse, abuse, negligence, accidents, repairs or alterations or lack of maintenance. This is Grizzly's sole written warranty and any and all warranties that may be implied by law, including any merchantability or fitness, for any particular purpose, are hereby limited to the duration of this written warranty. We do not warrant or represent that the merchandise complies with the provisions of any law or acts unless the manufacturer so warrants. In no event shall Grizzly's liability under this warranty exceed the purchase price paid for the product and any legal actions brought against Grizzly shall be tried in the State of Washington, County of Whatcom.

We shall in no event be liable for death, injuries to persons or property or for incidental, contingent, special, or consequential damages arising from the use of our products.

To take advantage of this warranty, contact us by mail or phone and give us all the details. We will then issue you a "Return Number", which must be clearly posted on the outside as well as the inside of the carton. We will not accept any item back without this number. Proof of purchase must accompany the merchandise.

The manufacturers reserve the right to change specifications at any time because they constantly strive to achieve better quality equipment. We make every effort to ensure that our products meet high quality and durability standards and we hope you never need to use this warranty.

Please feel free to write or call us if you have any questions about the machine or the manual.

Grizzly Industrial, Inc.
1203 Lycoming Mall Circle
Muncy, PA 17756
Phone: (570) 546-9663
Fax: (800) 438-5901

E-Mail:
techsupport@grizzlyindustrial.com

Web Site: <http://www.grizzly.com>

Thank you again for your business and continued support. We hope to serve you again soon.

NOTES

NOTES

WARRANTY CARD

Name _____

Street _____

City _____ State _____ Zip _____

Phone Number _____ E-Mail _____ FAX _____

- How did you learn about us?
 Advertisement Friend
 Catalog Card Deck
 World Wide Web
 Other _____
- What is your annual household income?
 \$20,000-\$29,999 \$60,000-\$69,999
 \$30,000-\$39,999 \$70,000-\$79,999
 \$40,000-\$49,999 \$80,000-\$89,999
 \$50,000-\$59,999 \$90,000 +
- What is your age group?
 20-29 50-59
 30-39 60-69
 40-49 70 +
- How long have you been a woodworker?
 0 - 2 Years 8 - 20 Years
 2 - 8 Years 20+ Years
- How would you rank your woodworking skills?
 Simple Advanced
 Intermediate Master Craftsman
- What stationary woodworking tools do you own?
Check all that apply.
 Air Compressor Panel Saw
 Band Saw Planer
 Drill Press Power Feeder
 Drum Sander Radial Arm Saw
 Dust Collector Shaper
 Spindle Sander Jointer _____
Table Saw Lathe
 Mortiser Wide Belt Sander
 Horiz.Boring Machine
 Vacuum Veneer Press
 Other _____
- How many of your woodworking machines are Grizzly? _____
- Which benchtop tools do you own? Check all that apply.
 1"x42" Belt Sander 6" - 8" Grinder
 5" - 8" Drill Press Mini Lathe
 8" Table Saw 8" - 10" Bandsaw
 Scroll Saw Disc/Belt Sander
 Spindle/Belt Sander Mini Jointer
 10"-12"Thickness Planer Other _____
- How many of the machines checked above are Grizzly? _____
- Which portable/hand held power tools do you own?
Check all that apply.
 Belt Sander Orbital Sander
 Biscuit Joiner Palm Sander
 Circular Saw Portable Planer
 Detail Sander Saber Saw
 Drill/Driver Reciprocating Saw

 Miter Saw Router _____
Other _____
- What machines/supplies would you like Grizzly Industrial to carry?
 12" Table Saw Radial Arm Saw
 12" Jointer Panel Saw
 Brass Hardware Lumber
 Paint & Finishing Supplies
 Contractor's Supplies
Combination Planer/Joiner Other _____
- What new accessories would you like Grizzly Industrial to carry?
 Builders Hardware Hand Tools
 Fasteners
 Wood Components _____
Other _____
- What other companies do you purchase your tools and supplies from? _____

- Do you think your purchase represents good value?
 Yes No
- Would you recommend Grizzly to a friend?
 Yes No
- Would you allow us to use your name as a reference for Grizzly customers in your area? Note: We never use names more than three times.
 Yes No

Send a Grizzly Catalog to a friend:

Name _____
Street _____
City _____ State _____ Zip _____

FOLD ALONG DOTTED LINE

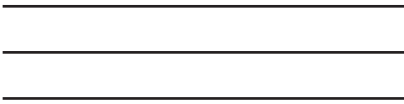

GRIZZLY INDUSTRIAL, INC.
P.O. BOX 2069
BELLINGHAM, WA 98227-2069

TAPE ALONG EDGES--PLEASE DO NOT STAPLE